

Service Manual

INTEGRAL[®] Disc Brake Axles Compact Bearing System

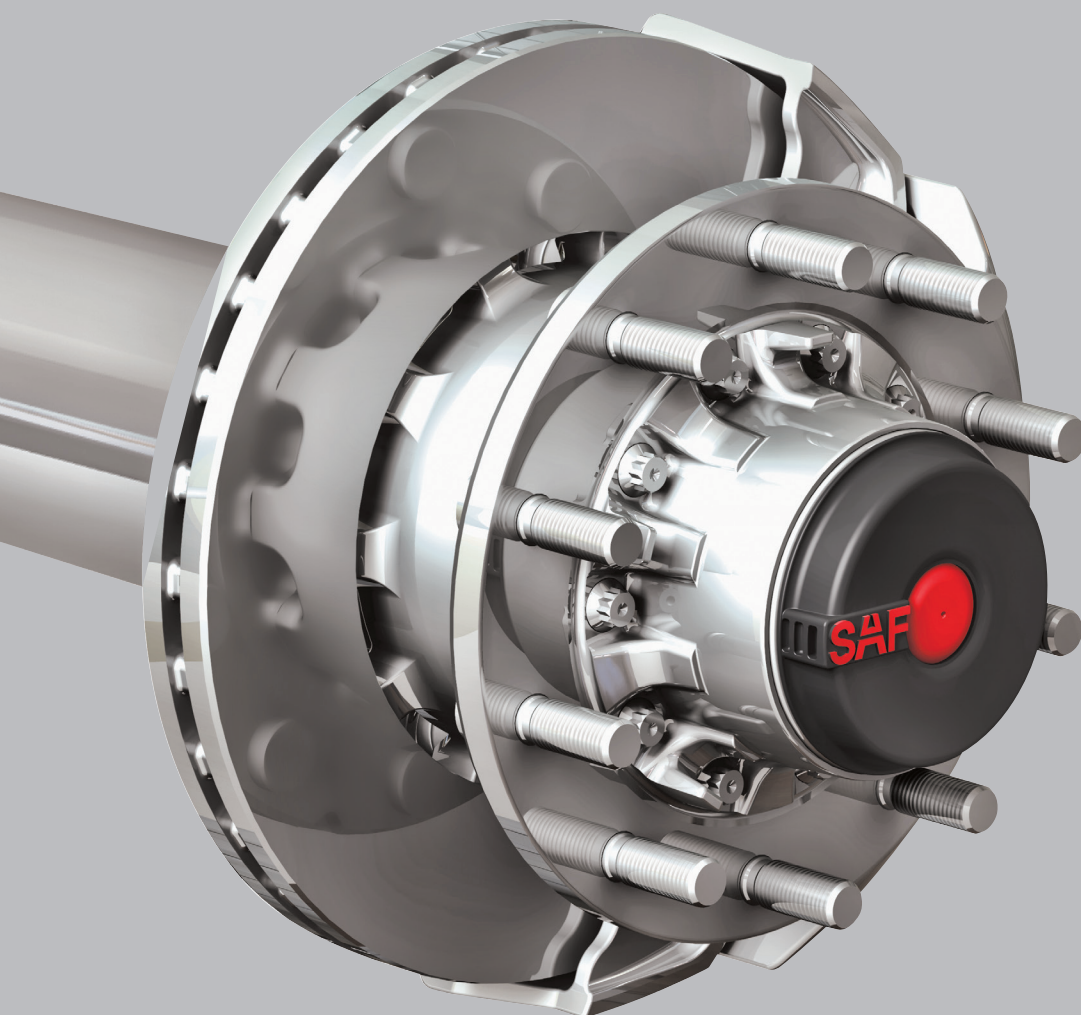

Contents	Page
Introduction.....	2
Warranty.....	2
Notes, Cautions, and Warnings.....	2
Section 1 – General Safety Instructions.....	3
Section 2 – General Service / Maintenance Instruction.....	4
Section 3 – Model Identification.....	5
Section 4 – Identification Tag.....	5
Exploded View and Parts List.....	6
Section 5 – Disc Brake/Hub Unit Inspection.....	7

Introduction

This manual provides the necessary information for the maintenance, inspection and safe operation of the SAF® disc brake system.

For axle end/brake replacement components contact SAF-HOLLAND® Customer Service at 888-396-6501.

Read this manual before using or servicing this product and keep it in a safe location for future reference. Updates to this manual, which are published as necessary, are available on the internet at www.safholland.us.

Use only SAF-HOLLAND® Original Parts to service your SAF-HOLLAND® INTEGRAL® disc brake axle. A list of technical support locations that supply SAF-HOLLAND® Original Parts and an Aftermarket Parts Catalog are available on the internet at www.safholland.us or contact Customer Service at 888-396-6501.

Warranty

Refer to the complete warranty for the country in which the product will be used. A copy of the written warranty is included with the product or available on the internet at www.safholland.us.

Contents	Page
Section 6 – Wheel Rock Test.....	10
Section 7 – Wheel Bearing Noise Test.....	10
Section 8 – Hub Unit Grease Leak Inspection.....	11
Section 9 – Servicing the Disc Brake/Hub Unit.....	12
Section 10 – Wheel Installation Procedure.....	18
Section 11 – Disc Brake Options.....	18
Section 12 – Torque Chart.....	20
Section 13 – Routine Service Schedule.....	21
Section 14 – Troubleshooting.....	22

Notes, Cautions, and Warnings

Knorr/Bendix is the manufacturer of the disc brake caliper assembly described in this service manual, NOT SAF-HOLLAND®. This manual references service documents which are published by Knorr/Bendix. The latest versions can be found on their website at www.bendix.com. These document references are intended to provide additional information when performing service work on the caliper assembly. SAF-HOLLAND® assumes no liability for the use of incorrect or unsuitable parts in the servicing or repair of the Knorr/Bendix disc brake caliper assembly. SAF-HOLLAND® assumes no liability for damages or claims arising out of incorrectly following procedures outlined in the Knorr/Bendix service manuals.

Knorr and Bendix are registered trademarks of the Knorr-Bremse Group.

Before starting any work on the unit, read and understand all the safety procedures presented in this manual. This manual contains the terms "NOTE", "IMPORTANT", "CAUTION", and "WARNING" followed by important product information. These terms are defined as follows:

NOTE: Includes additional information to enable accurate and easy performance of procedures.

IMPORTANT: Includes additional information that if not followed could lead to hindered product performance.

CAUTION Used without the safety alert symbol, indicates a potentially hazardous situation which, if not avoided, could result in property damage.

CAUTION Indicates a potentially hazardous situation which, if not avoided, could result in minor or moderate injury.

WARNING Indicates a potentially hazardous situation which, if not avoided, could result in death or serious injury.

1. Safety Instructions

General and Servicing Safety Instructions

- Read and observe all Warning and Caution hazard alert messages. The alerts provide information that can help prevent serious personal injury, damage to components, or both.

⚠ WARNING Failure to follow the instructions and safety precautions in this manual could result in improper servicing or operation leading to component failure which, if not avoided, could result in death or serious injury.

- All maintenance should be performed by a properly trained technician using proper/special tools, and safe procedures.

NOTE: In the United States, workshop safety requirements are defined by federal and/or state Occupational Safety and Health Act (OSHA). Equivalent laws may exist in other countries. This manual is written based on the assumption that OSHA or other applicable employee safety regulations are followed by the location where work is performed.

- Properly support and secure the vehicle from unexpected movement when servicing the unit.

⚠ WARNING Failure to properly support and secure the vehicle and axles prior to commencing work could create a crush hazard which, if not avoided, could result in death or serious injury.

- If possible, unload the trailer before performing any service procedures.
- After pre-positioning the brake chamber, slack adjuster and/or ABS system as instructed in this manual, always consult the manufacturer's manual for proper operation.
- Service both roadside and curbside of an axle. Worn parts should be replaced in sets. Key components on each axle's braking system, such as friction material, rotors and drums will normally wear over time.
- DO NOT paint the wheel contact surfaces between the wheel and hub.

IMPORTANT: The wheel contact surfaces MUST be clean, smooth and free from grease.

⚠ WARNING Failure to keep wheel and hub contact surfaces clean and clear of foreign material could allow wheel/hub separations which, if not avoided, could result in death or serious injury.

- Only the wheel and tire sizes approved by the trailer builder can be used.

Operational and Road Safety Instructions

- Before operating vehicle, ensure that the maximum permissible axle load is NOT exceeded and that the load is distributed equally and uniformly.
- Make sure that the brakes are NOT overheated from continuous operation.

⚠ WARNING Failure to minimize the use of brakes during overheating conditions could result in deterioration of brake efficiency which could result in death or serious injury.

- The parking brake MUST NOT be immediately applied when the brakes are overheated.

CAUTION If the parking brake is immediately applied to the brakes when overheated, the brake drums or discs could be damaged by different stress fields during cooling.

- SAF® axles require routine service, inspection and maintenance in order to maintain optimum performance, and operational safety as well as an opportunity to recognize natural wear and defects before they become serious. Refer to the Routine Service Schedule in Section 12.

⚠ WARNING Failure to inspect and maintain your SAF-HOLLAND® INTEGRAL® disc brake axle as outlined in Section 12 can result in brake or wheel bearing failure which, if not avoided, could result in death or serious injury.

IMPORTANT: Use only SAF-HOLLAND® Original Parts to service your SAF-HOLLAND® INTEGRAL® disc brake axle.

⚠ WARNING Failure to maintain your SAF-HOLLAND® INTEGRAL® disc brake with SAF-HOLLAND® Original Parts can result in brake or wheel bearing failure which, if not avoided, could result in death or serious injury.

- Observe the operating recommendation of the trailer manufacturer for off-road operation of the installed axles.

IMPORTANT: The definition of OFF-ROAD means driving on non-asphalt/non-concrete routes, e.g. gravel roads, agricultural and forestry tracks, on construction sites and in gravel pits.

IMPORTANT: Off-road operation of axles beyond the approved application design could result in damage and impair suspension system performance.

- Follow the recommended routine maintenance and inspections described in this manual. These procedures are designed so that optimum performance and operational safety are achieved.
- Contact a qualified towing and/or service company to assist in repairing vehicle or to move it to a qualified repair facility.

2. General Service/Maintenance

1. Conduct regular visual checks of the brakes, tires and all chassis components. Refer to Section 12 for more information:
 - a. Inspect for secure mounting, wear, leaks, corrosion and damage.
 - b. Check for loose, broken or cracked air hoses, air system leaks, and damaged components.
 - c. Check that brake hoses and cables are properly secured.
 - d. For proper brake pad wear, check that there is enough clearance to allow the caliper full movement during normal operation.
2. Check the brake pads at regular service intervals to ensure that the brake pad hold down springs are in the correct position, and that brake pads are NOT worn beyond the minimum wear limits described in this manual.
3. When replacing brake pads, inspect the rotors for signs of wear, cracks, grooves, scoring or hot spots.
4. Visually check the brake caliper at regular service intervals as defined by the brake caliper manufacturer's basic inspection program. Refer to Section 5.3 of this manual for further information.
5. Check the spring brake chambers to make sure the parking springs are NOT caged in the released position. Be sure the dust plugs are properly installed.
6. Make sure that the vent holes in the air brake chamber are NOT covered with snow, ice, mud, etc.
7. Inspect the wheel bearing unit for grease leaks at every brake pad change.
8. Visually check the brake assembly (e.g. pads, rotor, etc.) for oil or grease contamination.
9. Check that all dust caps and boots are present and in good condition.

10. Regularly conduct general safety checks in accordance with any applicable laws.
11. After every wheel change, the wheel nuts **MUST** be re-tightened to the specified torque level after the initial 100 miles of operation, and then at every regular service interval.

CAUTION

Failure to re-tighten wheel nuts at specified intervals could result in component failure which, if not avoided, could result in damage to property.

Use only SAF-HOLLAND® Original Parts to service your SAF-HOLLAND® INTEGRAL® disc brake axle.

3. Model Identification

The disc brake axle serial tag is located near the center of the axle tube (**Figure 1**).

Figure 1

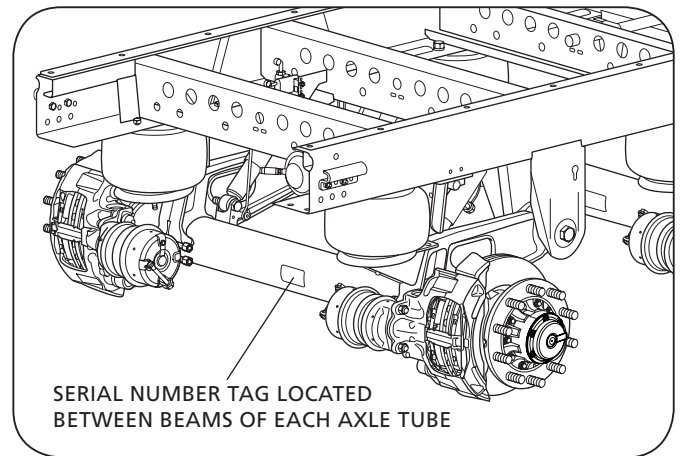

4. Identification Tag

The sample tag shown will help you interpret the information on the SAF-HOLLAND® USA, Inc. serial number tag. The model number, axle body part number and serial number are listed on the tag (**Figure 2**).

Record your tag numbers below for future quick reference.

Axle Body Part Number: _____

Model Number: _____

Serial Number: _____

Figure 2

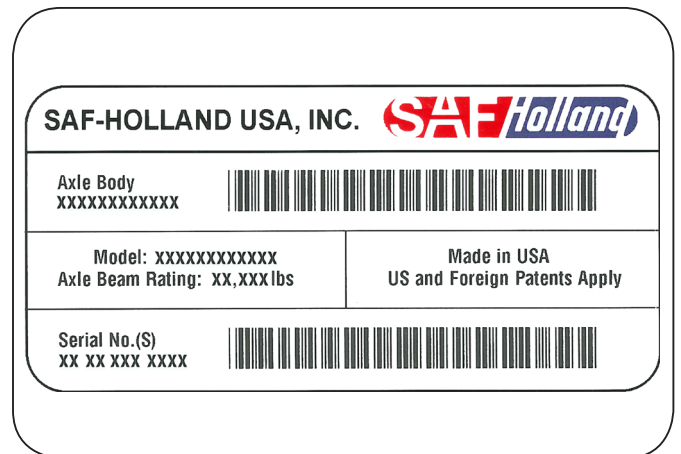

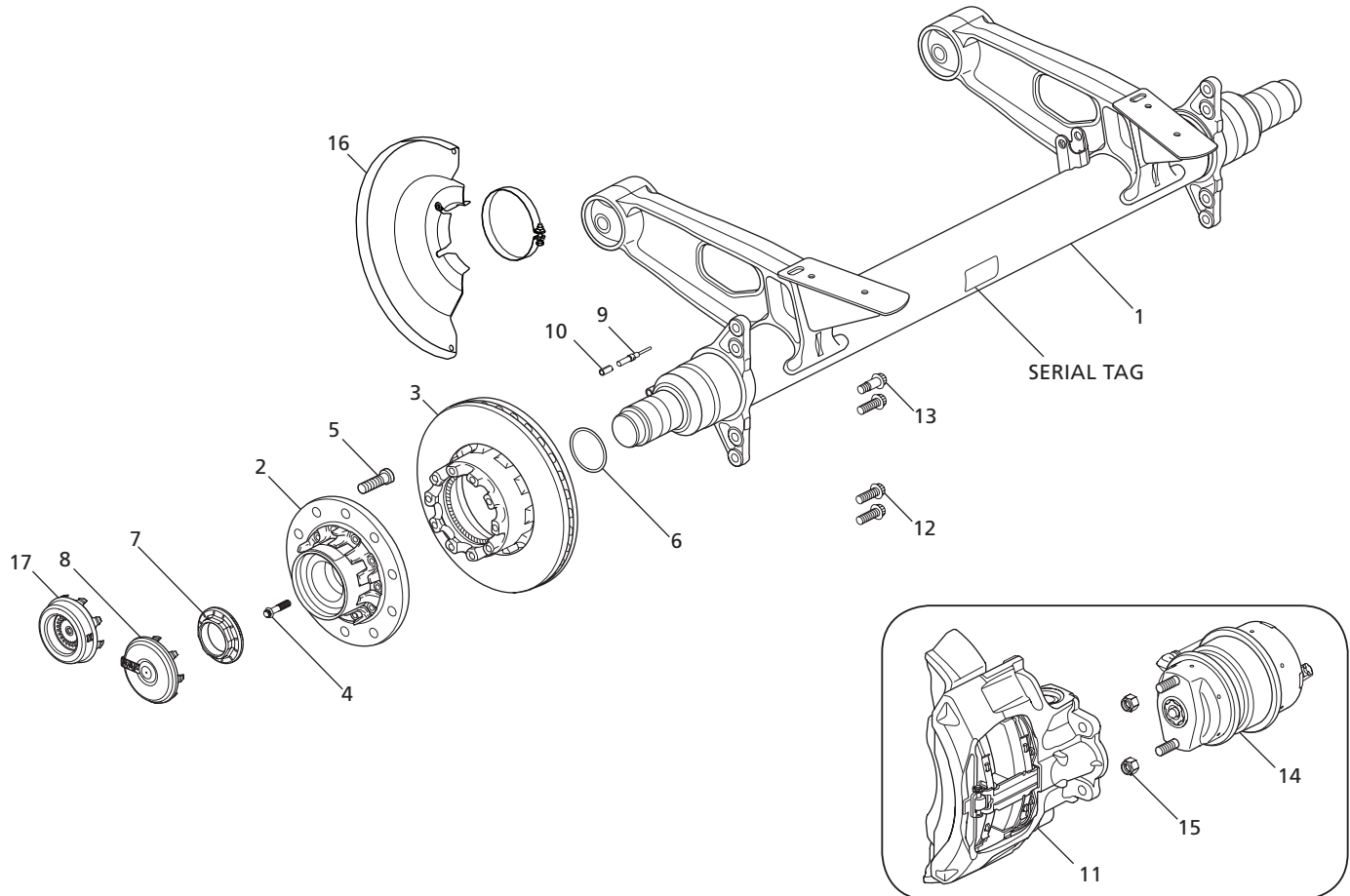

NOTE: Refer to the model number on the serial tag to identify your specific axle model's wheel end components. Contact SAF-HOLLAND® Customer Service at 888-396-6501.

ITEM NO.	DESCRIPTION	QTY. / AXLE
1	Axle Body	1
2	Hub with Compact Bearing	2
3	Rotor w/ Toner Ring	2
4	M 14 x 1.5 Bolt - Hub Rotor	20
5	Wheel Studs	20
6	O-Ring D92 x 4	2
7	Axle Nut Right-Hand	1
8	Axle Nut Left-Hand	1
9	Hub Cap with Seal	2
10	ABS Sensor (WABCO)	2

ITEM NO.	DESCRIPTION	QTY. / AXLE
10	Clamping Bush	2
11	Brake Caliper SK7, Right	1
12	Brake Caliper SK7, Left	1
13	M18 x 1.5 Bolt, Standard	6
14	M18 x 1.5 Bolt, Shoulder	2
15	Brake Chamber	2
16	Chamber Nut	4
17	Dust Shield (Optional)	2
18	Hub Odometer Cap (Optional)	1

5. Disc Brake/Hub Unit Inspection

IMPORTANT: During removal inspect components for wear and replace worn components.

⚠ WARNING Failure to properly support axle during maintenance could allow axle to fall which, if not avoided, could result in death or serious injury.

NOTE: For further disc brake inspection information, refer to the latest version of the TMC recommended practice RP 652–Service and Inspection of Air Disc Brakes (TMC DVD supplement).

5.1 Pad Wear Inspection

Check the brake pads for proper thickness at regular service intervals based on vehicle usage. Brake pad inspections should be carried out at least every three (3) months and in accordance with any legal requirements. Refer to "Routine Service Schedule" in Section 12.

NOTE: Regular service intervals could be required more frequently for severe duty applications. Refer to Section 12.

A quick visual inspection of the condition of the brake pads can be performed without removing the wheel:

1. Compare the position of the caliper marking to the carrier marking located on the underside of the caliper unit (**Figure 3**).
 - a. **Figure 3** - "View A" shows the positions of the two (2) markings when the brake pads are in good condition.
 - b. **Figure 3** - "View B" shows the positions of the two (2) markings when the wheel **MUST** be removed for further inspection of wear to the brake pads and brake rotor.

For further inspection of the brake pads, the wheel and brake pads **MUST** be removed. Refer to the Knorr/Bendix SK7 brake pad change service data sheet "SD-23-7541 Air Disc Brake" which can be found at www.bendix.com for more information.

IMPORTANT: After inspecting the brake pads, check that the brake system is functioning properly.

IMPORTANT: When replacing worn brake pads, **ALL** pads on the axle **MUST** be replaced.

If the friction material of the brake pad is less than 0.43" (11 mm) at its thinnest area, the brake pad **MUST** be replaced (**Figure 6**).

NOTE: Minor breakouts at the edges are permitted; major breakouts on the surface of the brake pad are **NOT** permitted (**Figure 4**).

Figure 3

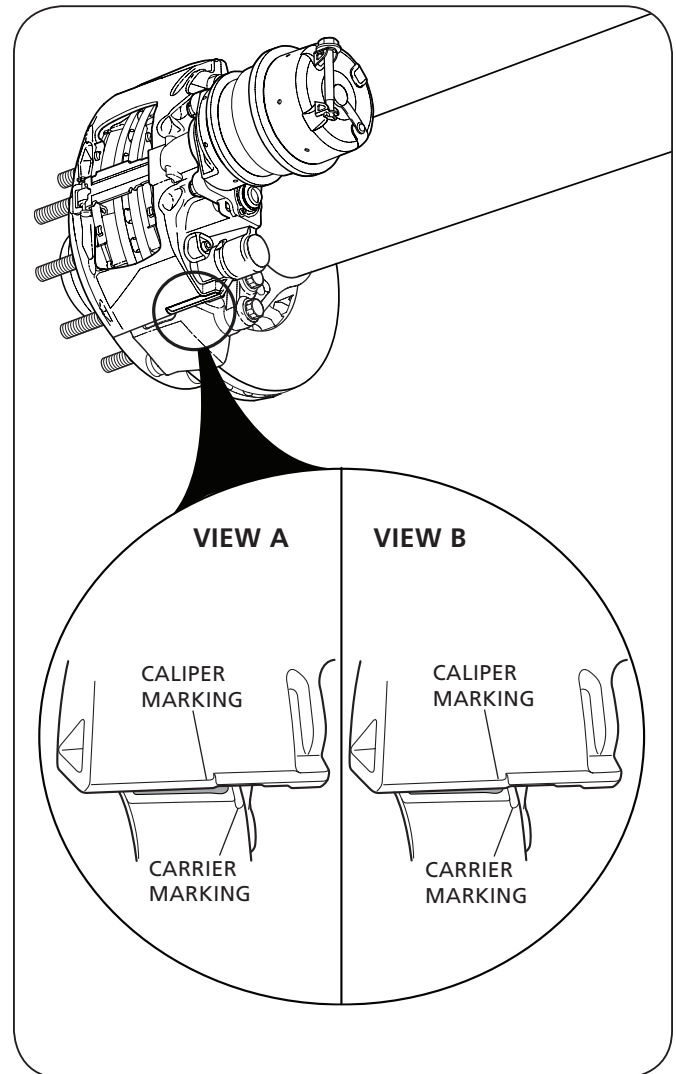
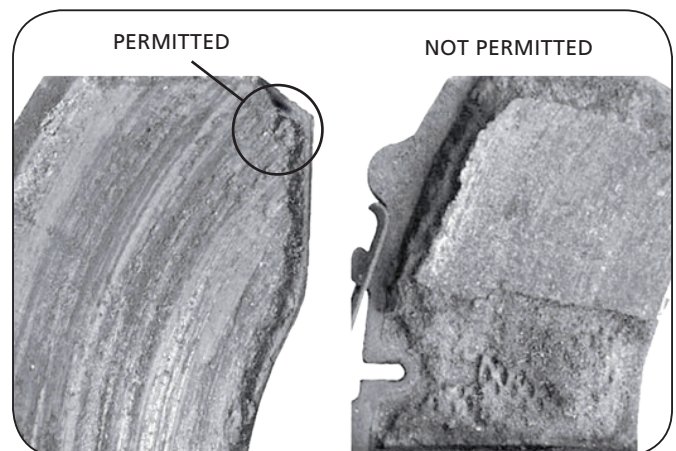

Figure 4



5.2 Rotor Wear Inspection

1. Carefully inspect both sides of the brake rotor friction surface (**Figure 5**).
 - a. Spider web cracking is acceptable (**Area A**).
 - b. Radial cracks less than 0.06" (1.5 mm) deep or wide and their length is less than 75% of the width of the rotor friction surface (**Area B**).
 - c. Grooves in the rotor surface are acceptable only if they are less than 0.06" (1.5 mm) deep (**Area C**).
 - d. Cracks that run completely to either edge of the hub are NOT acceptable, regardless of depth (**Area D**).
2. Measure the brake rotor thickness and re-surface, if necessary. For proper brake function, the minimum thickness for re-surfacing the brake rotor is defined as 1.54-1.57" (39-40 mm).

⚠ WARNING Re-surfacing the brake rotor beyond the minimum thickness could cause component failure which, if not avoided, could result in death or serious injury.

IMPORTANT: DO NOT use high-pressure cleaners or liquid cleaners on the brake rotor.

If the overall wear limits for the brake rotor and brake pads are exceeded (**Figure 6**), the rotor and pads **MUST** be replaced. Refer to brake pad and rotor replacement instructions as detailed in Section 9.1 and 9.2.

For both the inner and outer pads, the maximum brake pad wear difference is 0.2" (5.0 mm).

BRAKE ROTOR			BRAKE PAD	
DIAMETER	"A" NEW	"B" WEAR LIMIT	"C" NEW	"D" WEAR LIMIT
430 mm	45 mm	37 mm	30 mm	11 mm
16.93"	1.77"	1.46"	1.18"	0.43"

⚠ WARNING Failure to replace brake rotor and pads when minimum wear limits are reached could cause component failure which, if not avoided, could result in death or serious injury.

NOTE: When replacing the brake pads or brake rotor, use only Original SAF-HOLLAND® rotors and approved brake pads.

IMPORTANT: When replacing worn brake pads, all pads on the axle **MUST** be replaced.

NOTE: During brake repairs, conduct a visual inspection of the seals on the brake caliper. Refer to Section 5.3 for more information.

Figure 5

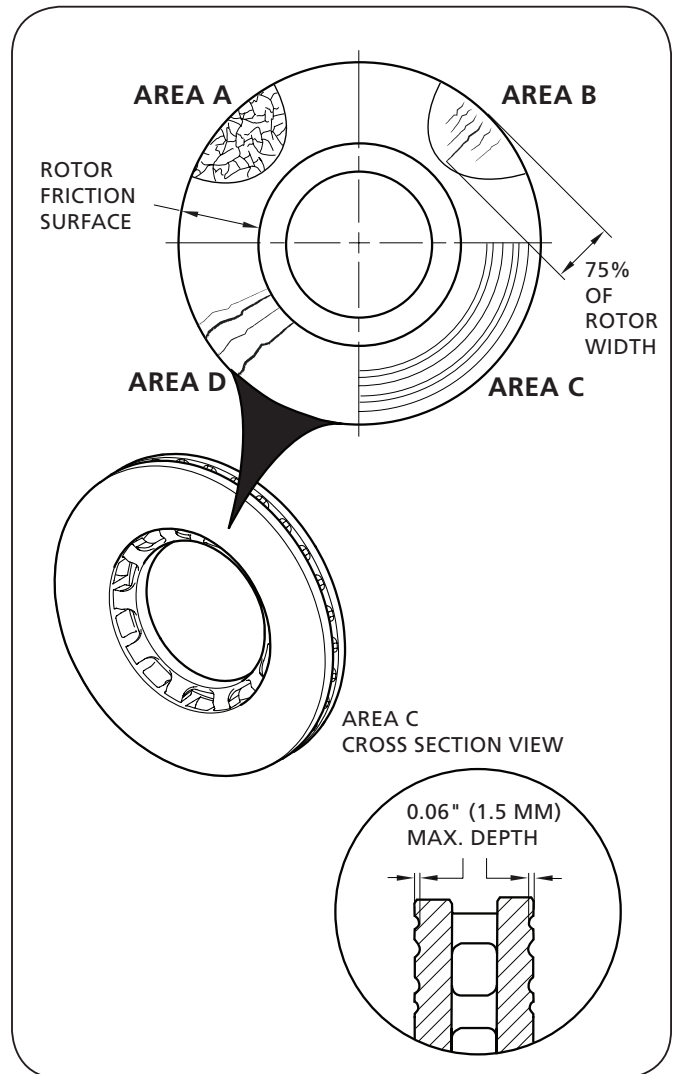
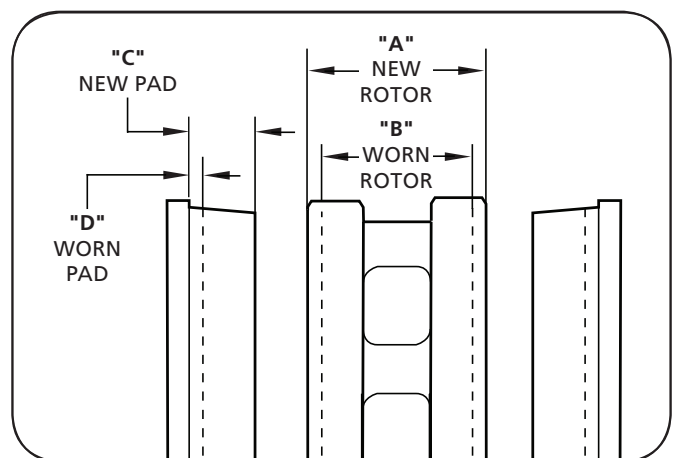

Figure 6



5.3 Brake Caliper Inspection

For instructions on brake caliper inspection and repair, refer to the Knorr/Bendix SK7 Caliper service data sheet "SD-23-7541 Air Disc Brake" which can be found at www.bendix.com.

5.4 Hub Unit Inspection

The SAF-HOLLAND® disc brake hub unit with compact bearing system is designed to be maintenance-free. If there is a malfunction with the hub unit, the hub unit including the compact bearing system **MUST** be replaced. The integrated compact bearing system is sealed and requires no additional grease or oil application to the bearing.

IMPORTANT: DO NOT remove the integrated compact bearing system. If there is a malfunction, the bearing system and hub unit **MUST** be replaced.

1. When changing brake pads and rotors or in the event of damage (e.g. brake overheating), inspect the bearing for signs of wear and grease leakage. Perform the Grease Leak Inspection, Wheel Rock Test and Wheel Bearing Noise Test as described in Sections 6 through 8.

⚠️ WARNING Failure to replace bearing system and hub unit when required could cause component failure which, if not avoided, could result in death or serious injury.

2. Visually check the seal system to ensure that it is functioning properly and that there is minimal grease leakage. Refer to Section 8 for more information. For guidance about diagnosing seal system malfunctions refer to Section 13.

NOTE: Adjustment of the compact bearing system is NOT necessary.

IMPORTANT: DO NOT use high-pressure cleaners or liquid cleaners on the hub unit.

IMPORTANT: The red dot in the middle of the SAF® plastic hub cap is permanent. If you attempt to remove it, hub cap failure will result.

⚠️ WARNING Failure to replace plastic hub cap when broken could cause component failure which, if not avoided, could result in death or serious injury.

6. Wheel Rock Test

1. For sufficient clearance to perform the test, raise the wheel off the ground. DO NOT remove the wheel!
2. Carefully remove the hub cap.
3. Using a size 85 mm socket, check the torque of the axle nut to ensure that it is torqued to 663 ft.-lbs. (900 N•m) by rotating the nut in either a left- or right-handed direction, for the roadside or curbside of the axle respectively.

NOTE: The SAF® compact bearing system uses a single piece spindle nut, which has a left-hand thread on the roadside of the axle and a right-hand thread on the curbside of the axle. The axle nut with a left-handed thread can be identified by a circular groove (**Figure 13**). The left-hand threaded axle spindle can be identified by a frontal groove on the end of the axle spindle.

4. Clean the surface of the axle nut. Attach the magnetic foot of the dial gauge to the surface of the nut and spindle. Place the pointer on the rim surface as shown (**Figure 7**).
5. Rock the wheel by first pulling at the top and pressing at the bottom, then pulling at the bottom and pressing at the top. Push and pull with approximately 50 lbs. (220 N) of force. While rocking/moving the wheel, record the end play shown on the dial gauge.

NOTE: Rotate the wheel several times before each measurement.

NOTE: If a recorded wheel end play of more than .01" (0.25 mm) while alternating +/- 50 lbs. (220 N) force is measured, the hub unit MUST be replaced.

7. Wheel Bearing Noise Test

1. For sufficient clearance to perform the test, raise the wheel off the ground. DO NOT remove the wheel!
2. Carefully remove the hub cap.
3. Using a size 85 mm socket, check the torque of the axle nut to ensure that it is torqued to 663 ft.-lbs. (900 N•m).
4. Rotate the wheel in both forward and rearward directions, using varying speeds (**Figure 8**).
5. If the bearing feels rough and/or a "grinding" noise is heard, the hub MUST be replaced.

NOTE: Noises can also be caused by the brakes. Before removing the hub unit, remove the brake pads and repeat the bearing noise test.

Figure 7

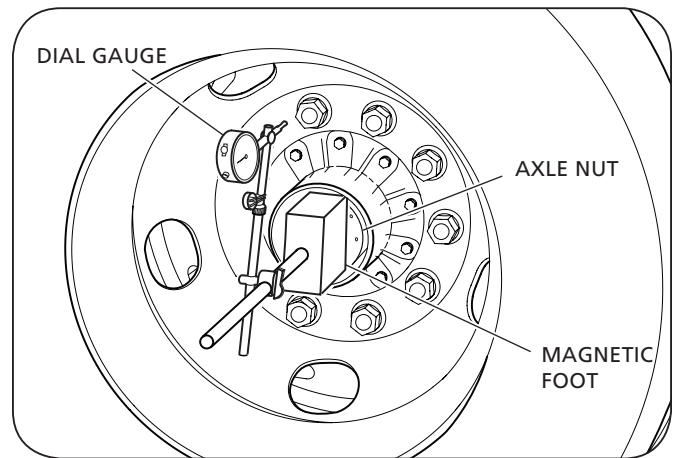
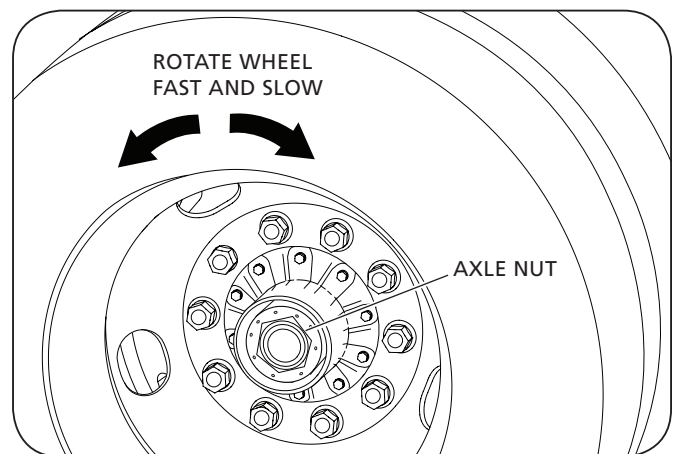

Figure 8



8. Hub Unit Grease Leak Inspection

A hub unit grease leak inspection should be performed if more than half of the wheel flange is covered with grease.

1. Carefully remove the hub cap.
2. Inspect the grease levels inside of the wheel flange including the inside of the hub cap, the axle nut, axle tube spindle and hub seal.
 - a. If the hub seal is **NOT** completely covered with grease (**Figure 9**), the hub units are correct and **DO NOT** need replacement.
 - b. If the hub seal is completely covered with tar-like grease (**Figure 10**), the hub unit **MUST** be replaced.

NOTE: There may be a small amount of grease on the lower edge of the hub seal. This is normal, and **DOES NOT** indicate grease leakage.

Figure 9



Figure 10



9. Disc Brake/Hub Unit Service

Contact SAF-HOLLAND® Customer Service at 888-396-6501 before performing any work on the SAF-HOLLAND® INTEGRAL® disc brake hub unit.

IMPORTANT: Only qualified mechanics should perform the procedures detailed in this manual.

NOTE: If the seal between the axle spindle and spindle nut is broken before the end of the stated warranty period, all warranty coverage will be invalidated unless the repair work has been approved by SAF-HOLLAND®. For approval, contact Customer Service at 888-396-6501.

IMPORTANT: During removal inspect components for wear and replace worn components.

⚠ WARNING Failure to properly support axle during maintenance could allow axle to fall which, if not avoided, could result in death or serious injury.

⚠ CAUTION DO NOT hit steel parts with a steel hammer as parts could break, sending flying steel fragments in any direction creating a hazard which, if not avoided, could result in minor to moderate injury.

NOTE: For certain service and repair work, some bolts MUST be replaced. DO NOT oil or grease bolts for installation. Tighten bolts with a torque wrench following the specified procedure and torque value. Refer to Torque Chart in Section 11.

9.1 Brake Pad Replacement

For instructions on brake replacement, refer to the Knorr/Bendix SK7 Caliper service data sheet "SD-23-7541 Air Disc Brake" which can be found at www.bendix.com.

IMPORTANT: After inspecting the brake pads, check that the brake system is functioning properly.

IMPORTANT: When replacing worn brake pads, all pads on the axle MUST be replaced.

9.2 Rotor Replacement

⚠ WARNING Failure to observe these instructions could cause component failure which, if not avoided, could result in death or serious injury.

- 1 Cage the spring brake.
- 2 Remove the ABS sensor by following the instructions detailed in Section 10.1.
- 3 Remove the brake chamber from the brake caliper by loosening and removing the two (2) mounting nuts (**Figure 11**).
- 4 Remove the brake caliper from the brake spider by using a size 24 mm socket to loosen and discard all four (4) brake caliper bolts (**Figure 12**).
- 5 Using a hub cap puller, remove the plastic hub cap (**Figure 13**) at the reinforced undercut on the side of the cap.

IMPORTANT: The red dot in the middle of the SAF® plastic hub cap is permanent and **MUST NOT** be removed.

- 6 Using a size 85 mm socket, remove the axle spindle nut by rotating the nut in either a left- or right-handed direction, respectively for the road or curbside of the axle.

NOTE: The SAF® compact bearing system uses a single piece spindle nut which has a left-hand thread on the roadside of the axle and a right-hand thread on the curbside of the axle. The axle nut with a left-handed thread can be identified by a circular groove (**Figure 13**). The left-hand threaded axle spindle can be identified by a frontal groove on the end of the axle spindle.

NOTE: DO NOT remove the SAF® compact bearing spindle nut with an impact wrench. Due to the self-tightening design of the SAF® compact bearing spindle nuts, it may be necessary to apply high torque of up to 1,600 ft.-lbs. (2,170 N•m) to loosen the spindle nuts. Use an appropriate length hand wrench and torque multiplier to loosen the SAF® compact bearing spindle nut.

IMPORTANT: DO NOT use an impact wrench to remove the SAF® compact bearing spindle nut.

⚠ CAUTION The high speed generated from air impact wrench to loosen the high clamp load of the SAF® compact bearing spindle nut could result in damage to the spindle threads.

Figure 11

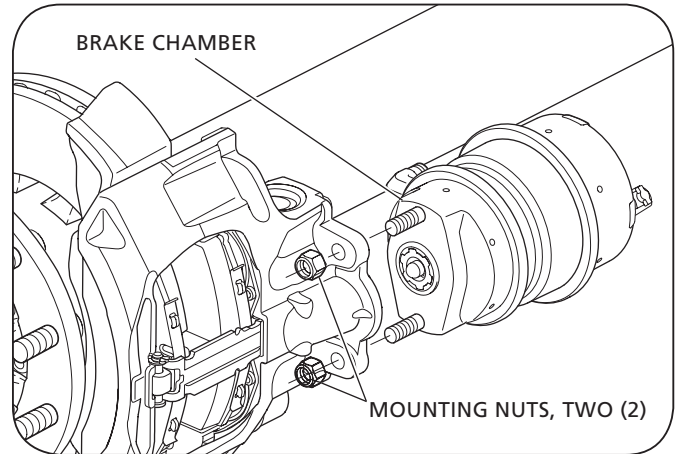

Figure 12

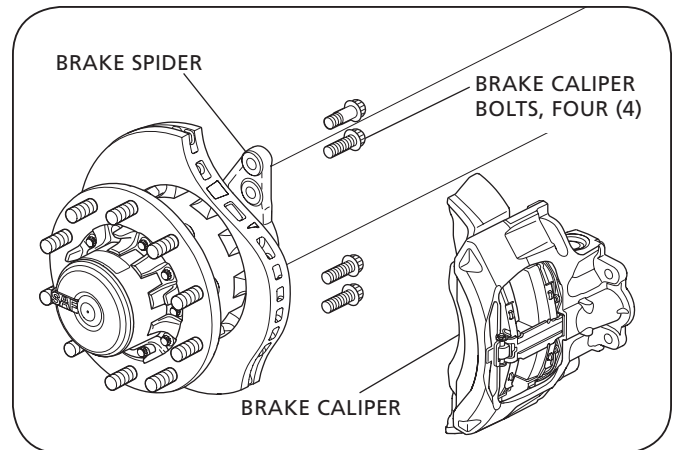
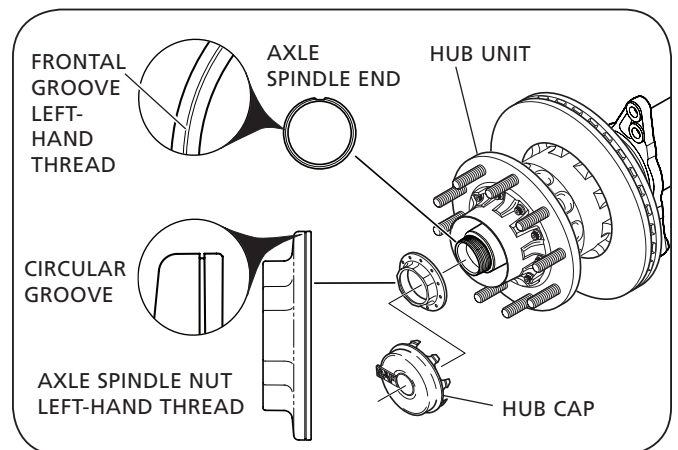

Figure 13



7. Remove the head unit by gently sliding it off the spindle. **(Figure 14).**
8. Remove the bearing O-Ring seal from the hub unit and discard **(Figure 15).**

NOTE: The O-Ring seal may be stuck to the bearing system or on the axle spindle.

9. Clean the hub unit bearing surface.
10. Remove the hub unit from the rotor by using a size 15 mm socket to loosen and discard all ten (10) connection bolts **(Figure 15).**
11. Clean the rotor contact surface on the hub unit. Using compressed air, clean the tapped holes in the disc unit. Check that the threads are in good working conditions.
12. Re-install the hub unit to the rotor by using ten (10) new SAF® specific connection bolts. Use a torque wrench to pre-torque the bolts to 37 ft.-lbs. (50 N•m). For final torque, tighten the bolts with an additional 120° turn using a criss-cross pattern. Refer to the Torque Chart in Section 11 for more information.

IMPORTANT: When re-installing the hub unit and rotor, use only new SAF® specific connection bolts. Bolts **MUST** be clean and free of oil and grease.

⚠ WARNING Failure to observe these instructions could cause component failure which, if not avoided, could result in death or serious injury.

13. Clean any grease residues from the axle spindle end and re-coat the bearing journal with Renolit Paste AZ 0-1. **DO NOT** grease or oil the spindle threads.

NOTE: Renolit Paste AZ 0-1 is available in 5 g packets through SAF-HOLLAND® Original Parts online at www.safholland.us or by contacting Customer Service at 888-396-6501.

IMPORTANT: **DO NOT** use high-pressure cleaners or liquid cleaners on the spindle.

14. Insert a new bearing O-Ring seal into the groove of the hub unit **(Figure 16).**
15. Re-install the head unit by gently sliding it on the spindle **(Figure 14).** During re-installation be sure the O-Ring seal is in the proper position.

Figure 14

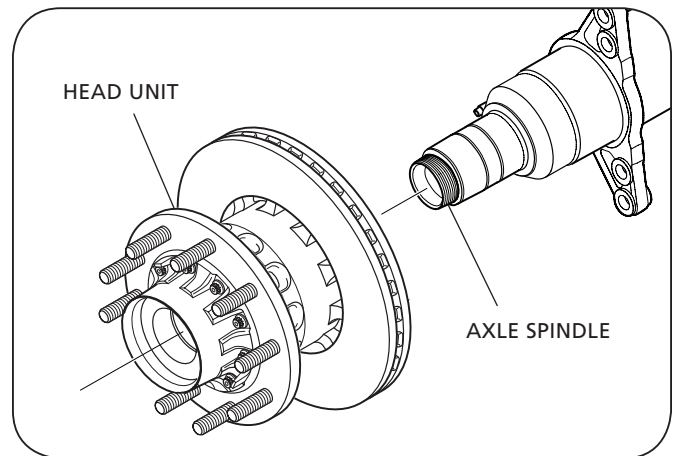

Figure 15

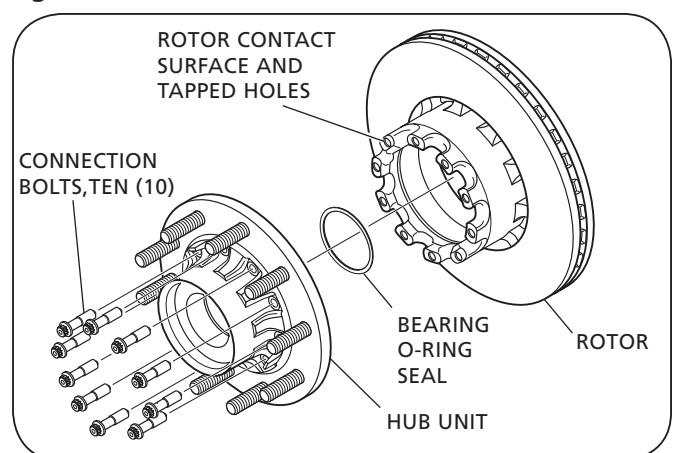
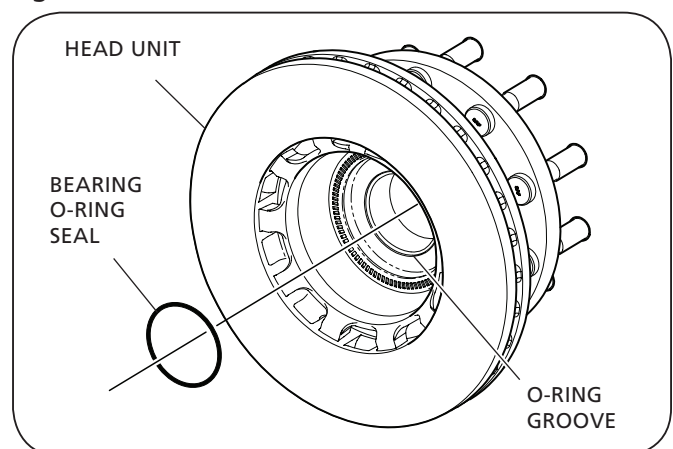

Figure 16



16. Re-install the SAF® specific axle spindle nut by rotating the nut onto the axle spindle in either a left-or right-handed direction, depending on the direction of the thread:

NOTE: The SAF® compact bearing system uses a single piece spindle nut which has a left-hand thread on the roadside of the axle and a right-hand thread on the curbside of the axle. The axle nut with a left-handed thread can be identified by a circular groove. The left-hand threaded axle spindle can be identified by a frontal groove on the end of the axle spindle (**Figure 13**).

- Pre-torque the axle spindle nut with a torque wrench and size 85 mm socket to 110 ft.- lbs. (150 N•m).
- Rotate the head unit slowly five (5) revolutions.
- For final torque tighten the axle spindle nut by 1/12 turn (30°).

NOTE: Each mark on the spindle nut equals 1/12 (30°) turn (**Figure 17**).

- Check that the axle spindle nut has a final torque of 663 ft.-lbs. (900 N•m). Refer to the Torque Chart in Section 11.

NOTE: The maximum permissible end play of the hub unit is shown in Section 6.

17. Check that the hub cap O-Ring seal is in good condition and replace if necessary.
18. Re-install the hub cap onto the hub unit by pressing it slowly and uniformly against the hub seat until the snap fit is secure (**Figure 17**). Visually inspect for a proper O-Ring seal.
19. Re-install the caliper to the brake spider using four (4) new SAF® specific brake caliper bolts (**Figure 18**).

Figure 17

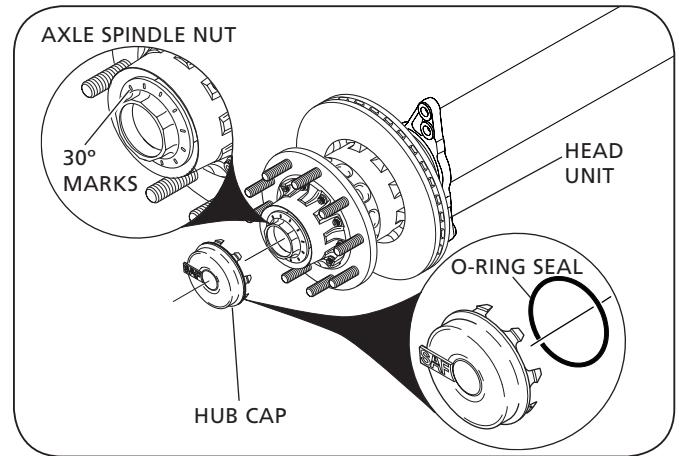
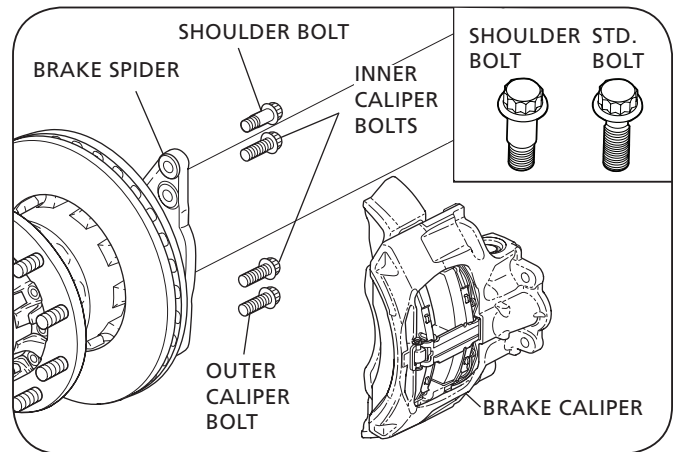

Figure 18



NOTE: The caliper is connected to the disc brake spider using four (4) SAF® specific bolts: three (3) standard bolts and one (1) shoulder bolt (**Figure 19**). The shoulder bolt is located at the outer mounting hole where the brake rotor rotates OUT of the caliper when turning in driving direction (**Figure 19**).

WARNING Failure to install the shoulder bolt in the proper location could cause component failure which, if not avoided, could result in death or serious injury.

- Pre-torque the bolts to 88 ft.-lbs. (120 N•m) from inner bolts to outer bolts using a size 24 mm socket.
- Verify the pre-torque of the bolts a second time, and if necessary re-tighten all bolts to 88 ft.-lbs. (120 N•m).
- Final torque from inner bolts to outer bolts to 331 +/- 22 ft.-lbs. (450 +/- 30 N•m).

IMPORTANT: Make sure that the brake caliper is mounted on the correct side of the axle. The correct location can be identified by the lengths of the guide pins on the caliper unit. The longer guide pins should be located on the bottom of the caliper unit when installed on the axle in driving direction. The shorter guide pins should be located on the top of the caliper unit (**Figure 20 and 21**).

- Re-install the SAF® brake chamber by following the instructions in "SAF® Brake Cylinders for Disc Brakes Installation and Service Guide" available online at www.safholland.us.
- Re-install the ABS sensor by following the instructions detailed in Section 10.1.
- To enable the ABS sensor to function properly press the ABS sensor against the toner ring at the hub unit to eliminate any clearance between these parts.

IMPORTANT: After replacing the rotor, verify that the brake system is functioning properly.

9.3 Brake Caliper Servicing

For instructions on brake caliper and repair/replacement, refer to the Knorr/Bendix SK7 Caliper service data sheet "SD-23-7541 Air Disc Brake" which can be found at www.bendix.com.

Figure 19

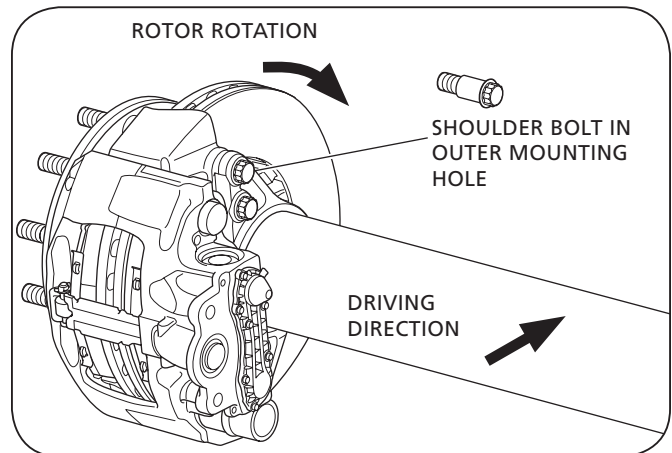

Figure 20

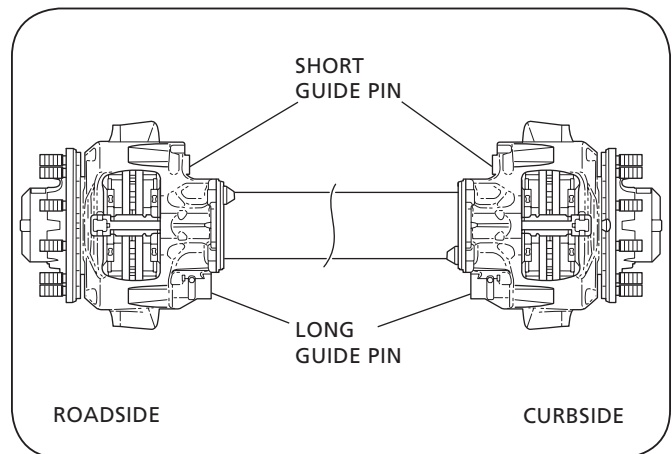
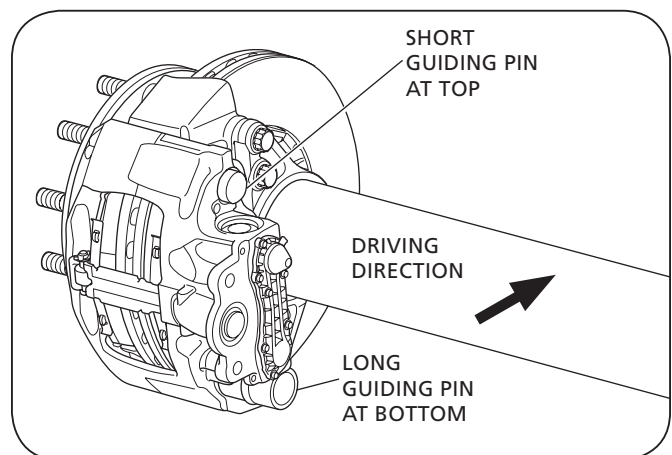

Figure 21



9.4 Hub Unit Servicing

The SAF-HOLLAND® disc brake hub unit with compact bearing system is designed to be maintenance-free. If there is a malfunction with the hub unit, the hub unit including the compact bearing system **MUST** be replaced. The integrated compact bearing system is lifetime sealed and requires no grease or oil application to the bearing.

IMPORTANT: DO NOT remove the integrated compact bearing system. If there is a malfunction, the bearing system and hub unit **MUST** be replaced.

When replacing the wheel bolts, refer to the hub removal instructions described in Section 9.2

NOTE: Not all bolts may need to be replaced. Only replace bolts that are damaged or in need of replacement.

1. Remove the wheel bolts by pressing them out of the hub unit and discard (**Figure 22**).
2. Install new wheel bolts by pressing them into the hub unit. To ensure correct alignment of the bolts during installation, position the flat side of each wheel bolt head so that it is facing the center of the hub (**Figure 23**).

CAUTION DO NOT hit steel parts with a steel hammer as parts could break, sending flying steel fragments in any direction creating a hazard which, if not avoided, could result in minor to moderate injury.

Figure 22

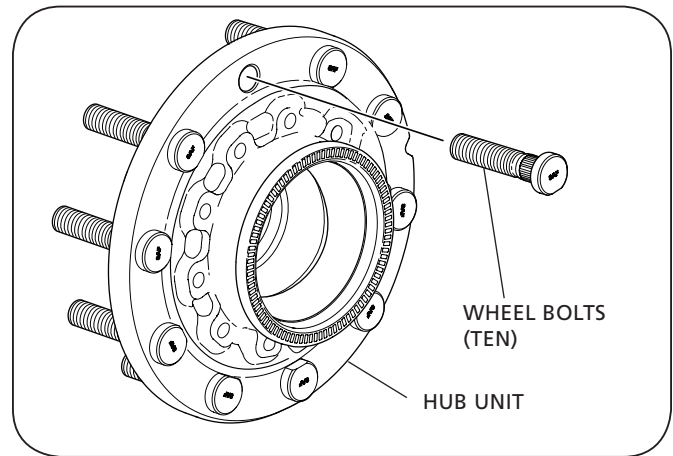
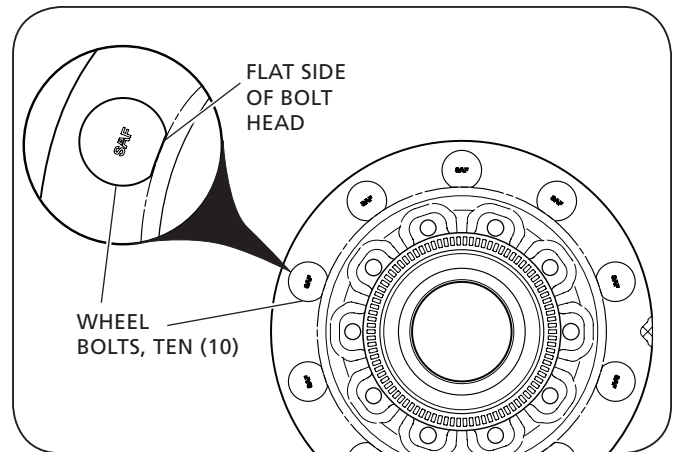

Figure 23



10. Wheel Installation Procedure

The following information is intended to provide basic wheel installation instructions. Refer to TMC RP222C for complete installation details.

1. Clean all mating surfaces on hub, wheels and nuts.
2. Rotate the hub so a pilot boss is at the top (12 o'clock) position.
3. Mount wheel(s) on hub. One or more of the wheel nuts can be started in order to hold wheel in position.
4. Tighten the top wheel nut first. Apply 50 ft.-lbs. (68 N•m) of torque to draw the wheel up fully against the hub.
5. Install remaining wheel nuts. Using sequence shown in **(Figure 24)**, tighten all wheel nuts to 50 ft.-lbs. (68 N•m) of torque.
6. Repeating sequence shown in **(Figure 24)**, retighten all wheel nuts to 475 ± 25 ft. lbs. (644 ± 34 N•m) of torque.
7. Check seating of wheel at the pilot bosses. Rotate wheel and check for any rotational irregularity.

⚠ WARNING Retorque all wheel nuts after 5 to 100 miles of service on the initial "in-service" following any installation of wheel to hub assembly.

11. Disc Brake Options

11.1 ABS Sensor Replacement

NOTE: When replacing the ABS sensor, only install a sensor manufactured by WABCO. DO NOT mix sensors from different manufacturers. The SAF-HOLLAND® INTEGRAL® Disc Brake comes with a WABCO ABS mini sensor Ø11. For further ABS sensor information, contact SAF-HOLLAND® Customer Service at 888-396-6501.

1. Disconnect the ABS sensor.
2. Remove the ABS sensor from the sensor holder by pulling it straight out from the holder and discard **(Figure 25)**.
3. If necessary, remove the sensor retaining spring clip from the sensor holder and replace with new clip. **(Figure 25)**.
4. Install a new ABS sensor by pushing it directly into the sensor holder/spring clip until it contacts the tooth wheel in the hub unit **(Figure 25)**.
5. Re-connect the ABS sensor.

Figure 24

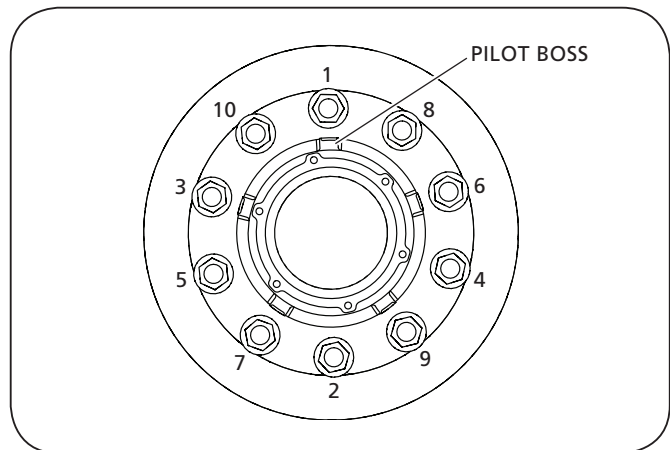
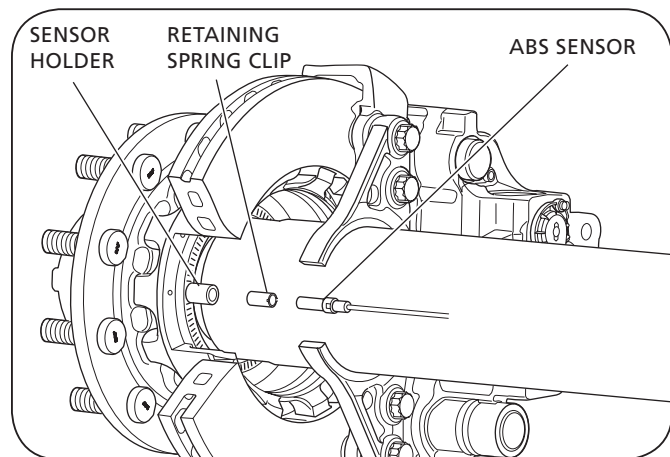

Figure 25



11.2 Hubodometer

The SAF-HOLLAND® INTEGRAL® Disc Brake can be factory equipped or retrofitted with a hubodometer hub cap for installation of a hubodometer.

1. Remove the original plastic hub cap (**Figure 26**) at the reinforced undercut on the side of the cap using a hub cap puller.
2. Install hubodometer onto hubodometer hub cap.
3. Check that the hubodometer hub cap O-Ring is installed correctly and is in good condition.
4. Install the hubodometer hub cap by pressing it slowly and uniformly against the hub seat until the snap fit is secure (**Figure 27**). Visually inspect the O-Ring for a proper seal.

NOTE: A hubodometer hub cap cannot be installed on axles equipped with a Tire Inflation System (TIS).

11.3 Tire Inflation System

If your system is prepped for a Tire Inflation System, contact SAF-HOLLAND® Customer Service for further information and installation instructions.

11.4 Dust Shield

The SAF-HOLLAND® INTEGRAL® Disc Brake can be factory equipped or retrofitted with a dust shield.

Refer to **Figure 28** for the following instructions:

1. Using a 13mm socket, loosen and remove the dust shield clamp band bolt.
2. Wrap the clamp band around the axle and loosely install the clamp band bolt.
3. Position the clamp band around the axle.
4. Route any ABS sensor wires through one of the two rubber grommets on the dust shield.
5. Position the clamp band over the clamp band lip portion of the dust shield.
6. Slide the dust shield and clamp band together toward the disc brake until the clamp band is about 12mm (0.5") from the brake rotor, pulling the ABS sensor wire through the rubber grommet as necessary.
7. Torque the clamp band bolt to 20-25 ft.-lbs. (27-34 N•m).
8. Use a pry bar and/or rubber mallet to ensure that there is clearance between the dust shield and the rotor.
9. Plug the ABS sensor into the abs system wire.

Figure 26

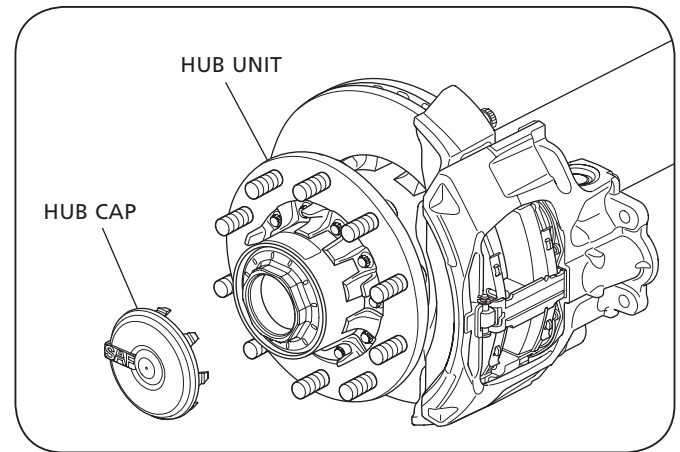

Figure 27

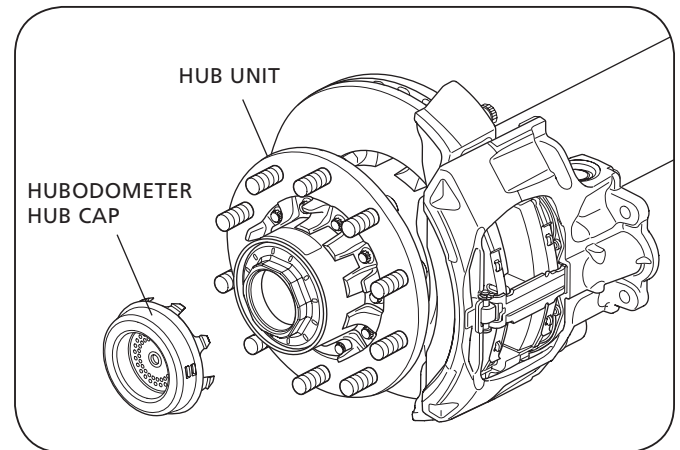
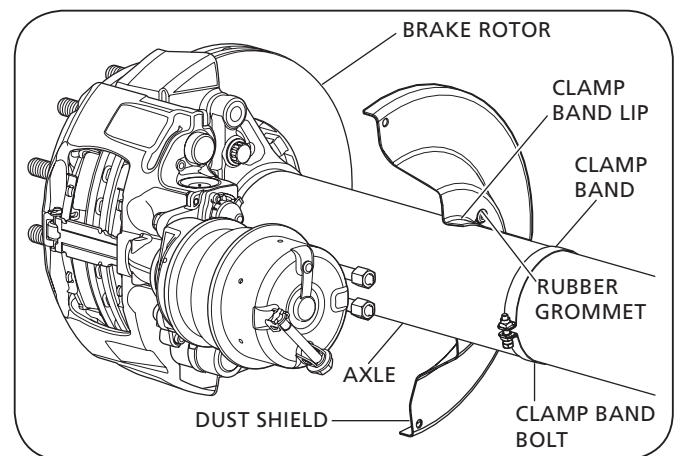

Figure 28



12. Torque Chart

PART	APPLICATION	TORQUE SPECIFICATIONS
SAF® Specific Axle Spindle Nut M75 x 1.5	Compact Bearing System	<p>Left-hand thread located on the roadside of the axle. Right-hand thread located on the curbside of the axle. The axle nut with a left-handed thread can be identified by a circular groove (Figure 13).</p> <ol style="list-style-type: none"> 1. Pre-torque with a size 85 mm socket to 110 ft.-lbs. (150 N•m). 2. Rotate the head unit slowly five (5) revolutions. 3. For final torque tighten the axle spindle nut by 1/12 turn (30°). 4. Check that the axle spindle nut has a final torque of at least 663 ft.-lbs. (900 N•m). <p>Maximum permissible end play of the hub unit is shown in Section 6.</p>
SAF® Specific INTEGRAL® Bolt M14 x 1.5	Rotor - Hub	<p>Torque all ten (10) bolts in a criss-cross pattern.</p> <ol style="list-style-type: none"> 1. Pre-torque to 37 ft.-lbs. (50 N•m). 2. For final torque tighten by an additional 120° turn.
SAF® Specific Caliper Bolt M18 x 1.5	Caliper - Spider	<p>Torque bolts from inner bolts to outer bolts.</p> <ol style="list-style-type: none"> 1. Pre-torque to 88 ft.-lbs. (120 N•m). 2. Verify the pre-torque of the bolts a second time, and, if necessary re-tighten all bolts to 88 ft.-lbs. (120 N•m). 3. Final torque from inner bolts to outer bolts to 331 +/- 22 ft.-lbs. (450 +/- 30 N•m).
SAF® Specific Brake Chamber Nut 5/8"-11 UNC Nylock or M16 x 1.5"	Brake Chamber	<ol style="list-style-type: none"> 1. Pre-torque both chamber nuts to 60-75 ft.-lbs. (80-100 N•m). 2. For final torque tighten both chamber nuts to 130-155 ft.-lbs. (180-210 N•m)

13. Routine Service Schedule

⚠️ WARNING Failure to inspect and maintain your SAF-HOLLAND® INTEGRAL® disc brake axle as outlined in Section 12 can result in brake or wheel bearing failure which, if not avoided, could result in death or serious injury.

⚠️ WARNING Failure to maintain your SAF-HOLLAND® INTEGRAL® disc brake with SAF-HOLLAND® Original Parts can result in brake or wheel bearing failure which, if not avoided, could result in death or serious injury.

IMPORTANT: Use only SAF-HOLLAND® Original Parts to service your SAF-HOLLAND® INTEGRAL® disc brake axle.

WHICHEVER OCCURS FIRST	PERIODIC CHECKS				
	MILEAGE INTERVALS	After First 3,000 Miles	Daily	Every 20,000 Miles	Every 50,000 Miles
	TIME INTERVALS	After First Month		Every 3 Months	Every 6 Months
VISUAL AND SAFETY INSPECTION					
Inspect for missing, or loose hubcap.			•		
Inspect for grease leakage around hubcap.			•		
Hub unit maintenance-free. Check for grease leaks. Refer to Section 8.				•	
Inspect the brake caliper guide system. Check for free movement and sliding action. Refer to Section 5.3.					•
Check rubber dust covers for cracks and damage. Check adjuster cap for correct seating. Refer to Section 5.3.					•
Inspect brake pad thickness regularly. Refer to Section 5.				•	
Inspect brake rotors for cracks. Refer to Section 5.					•
Perform general service / maintenance inspection. Refer to Section 4.		•			
Perform disc brake / hub unit inspection. Refer to Section 5.		•			•
Perform wheel rock and wheel noise tests. Refer to Section 6 and 7.				•	

MECHANICAL CHECK
Attention: Check torque of wheel nuts after the first 5-100 miles (8-160 km) from date vehicle was placed into service and after every wheel removal. Continually check wheel torque every 10,000 miles (16,000 km), or at the intervals indicated in your vehicle owner's manual, whichever occurs first.

SPECIAL SERVICE CONDITIONS	
Vehicles with long standing periods.	Service at specified time intervals, e.g. trailer used for storage or frequently left standing for several days at a time.
Vehicles used under severe duty and extreme conditions.	Service at suitably reduced intervals, e.g. trailer operating in continuous multi-shifts or in off-road construction sites.

14. Troubleshooting Chart (SAF-HOLLAND® suspensions equipped with disc brake axles)

PROBLEM	POSSIBLE CAUSE	POSSIBLE REMEDY
Brakes will NOT release	Disc brake caliper bound up	Lubricate or replace brake caliper
	Brake hoses restricted	Replace hoses
	Brake control valve restricted/inoperable	Repair/replace control valve
	Brake out of adjustment	Adjust brake/repair or replace automatic adjustment device as necessary
	Damaged brake chamber	Replace brake chamber
	Damaged brake assembly	Replace or repair brake assembly
	Supply air interrupted	Open glad hand cut-out cock or push brake control valve in
	Supply line improperly coupled	Properly couple supply air line
	Brake pads frozen to rotor in cold weather	Warm brakes
No brakes or insufficient brake performance	Service air interrupted	Open glad hand cut-out cock
	Service air line improperly coupled	Properly couple service air line
	Brake hoses restricted	Relieve restriction or obstruction or replace hoses
	Brake control valve restricted/inoperable	Repair/replace control valve
	Brake out of adjustment	Adjust brake/repair or replace automatic adjustment device as necessary
	Damaged brake chamber	Replace brake chamber
	Damaged brake assembly	Replace or repair brake assembly
Dragging Brakes/Slow brake application or release timing	Brake hoses restricted	Relieve restriction or obstruction or replace hoses
	Brake control valve restricted/inoperable	Repair/replace control valve
	Brake out of adjustment	Adjust brake/repair or replace automatic adjustment device as necessary
	Damaged brake chamber	Replace brake chamber
	Damaged brake assembly	Replace or repair brake assembly
Dog tracking	Axle not properly aligned	Align axle
	Slider assembly racked or NOT aligned properly	Repair or replace slider assembly
	Frame bent or NOT aligned properly	Repair or align frame
	Damaged suspension component	Repair or replace suspension component
	Bent axle	Replace axle
Uneven tire wear	Improper tire inflation	Inflate tire to proper pressure
	Loose wheel stud nuts	Inspect for and repair any resultant wheel end damage and tighten properly
	Improper wheel bearing adjustment	Inspect for and repair any resultant wheel end damage and adjust properly
	Axle NOT properly aligned	Align axle
	Slider assembly racked or NOT aligned properly	Repair or replace slider assembly
	Frame bent or NOT aligned properly	Repair or align frame
	Damaged suspension component	Repair or replace suspension component
	Bent axle	Replace axle
	Mismatched tire sizes	Properly match tire sizes
	Unequal brake balance or timing	Repair brakes as necessary
	Overly aggressive braking	Instruct/train driver in proper brake use
	High speed turns	Instruct/train driver in proper vehicle speeds
	High level of side scrub	Instruct/train driver in proper vehicle maneuvering
Anti-Lock Brake System malfunction	Refer to ABS manufacturer's service literature	

PROBLEM	POSSIBLE CAUSE	POSSIBLE REMEDY
Grabbing brakes	Contaminants on brake lining	Replace brake pads
	Brake out of adjustment	Adjust brake/repair or replace automatic adjustment device as necessary
	Warped brake rotor	Machine or replace brake rotor
	Damaged brake chamber	Replace brake chamber
	Damaged brake assembly	Replace or repair brake assembly
	Unequal brake balance or timing	Repair brakes as necessary
	Anti-Lock Brake System malfunction	Refer to ABS manufacturer's service literature
Excessive heat cracks in rotor	Brake out of adjustment	Adjust brake/repair or replace automatic adjustment device as necessary
	Overly aggressive braking	Instruct/train driver in proper brake use
	Unequal brake balance or timing	Repair brakes as necessary
	Anti-Lock Brake System malfunction	Refer to ABS manufacturer's service literature
	Damaged brake chamber	Replace brake chamber
	Damaged brake assembly	Replace or repair brake assembly



From fifth wheel rebuild kits to suspension bushing repair kits, SAF-HOLLAND Original Parts are the same quality components used in the original component assembly.

SAF-HOLLAND Original Parts are tested and designed to provide maximum performance and durability. Will-fits, look-alikes or, worse yet, counterfeit parts will only limit the performance potential and could possibly void SAF-HOLLAND's warranty. Always be sure to spec SAF-HOLLAND Original Parts when servicing your SAF-HOLLAND product.

SAF-HOLLAND USA • 888.396.6501 • Fax 800.356.3929
www.safholland.us

SAF-HOLLAND CANADA • 519.537.3494 • Fax 800.565.7753
WESTERN CANADA • 604.574.7491 • Fax 604.574.0244
www.safholland.ca

SAF-HOLLAND MEXICO • 52.55.5362.8743 • Fax 52.55.5362.8743
www.safholland.com.mx

info@safholland.com